



PROTECHNIC ELECTRIC CO., LTD.

SPECIFICATION FOR APPROVAL

CUSTOMER:

MODEL: MGT4012UB-W28

P/N:

Rev: 01

Date: 2014-03-26

CUSTOMER APPROVAL
APPROVED / DATE

Rev	Description
01	

Notice:

This offer is made according to your current inquiry. Unless otherwise revised, this specification will be final for all future production of orders from your company.

Kindly study in detail and send back to us the specification sheets with your confirmation signature in order to make an arrangement for production.

Approved by	Checked by	Authorized by
馬孝菊 2014-03-26	江成林/鄭旭峰 2014-03-26	楊倩 2014-03-26

PRODUCT SAFETY

1. Protechnic will not guarantee this product if it is used in conditions other than the parameters outlined in this specifications
2. Please contact Protechnic to confirm any customer requirements not specified in the specification
3. Please handle fans carefully. Damage may result from pressure to the impeller, carrying by the lead wires, or dropping fans on a hard surface
4. The introduction of power, dust water insects or other erosion elements into the hub will result in safety problems or product failure, except in products designed for special environments.
5. Items 1-4, mentioned above, are generally pertinent to our products, and should be a first point of reference.
6. It is very important to establish the correct polarity before connecting the fan to the power source, Positive (+) and Negative (-). Damage may be cause by connecting with reverse polarity.
7. Avoid operating Protechnic products in environments where poisonous or corrosive elements are present (organic, silicon, cyanogens, formal in phenol, H₂S, SO₂, NO₂, CL₂, etc)
8. Please ensure that fans are stored according to the storage temperature specified. Do not store in a high humidity environment. If fans are stored for more than 6 mouths, Protechnic recommends testing of fans before using.
9. Not all series fans are provided with the lock rotor protection feature. Damage or failure will result from operating fans without this feature, if the impeller for the fan is in any way hindered or impaired.
10. Install fans carefully. Incorrect mounting or installation may result in excessive resonance, vibration and subsequent noise.
11. Safety is a top priority. Please utilize guard accessories to prevent injury to personnel.
12. Unless otherwise noted, all tests are conducted at 25°C ambient temperature, and 65% relative humidity.
13. When using multiple fans in parallel, connect an 'over 4.7μF 'capacitor externally to the fan to prevent abnormity resulting from unstable power.
14. Any change to the parameters specified in this specification will be determined by mutual agreement between both parties. Parameters not specified will be identical to the final sample approved by your company.

ITEMS	DESCRIPTION
Rated Voltage	D.C.12.0V
Operating voltage	D.C.6V~13.8V
Start up voltage	D.C.6V (At 25°C Power ON/OFF)
Pulse Power operating	If duty cycle is 50% ,the frequency should ≥ 10 Hz
Current	≤ 0.55 A
Power	6.6W
Speed	18000 $\pm 10\%$ rpm (At 25°C ,To record speed after fan running normal, This time about 3~5minutes)
Air flow (at zero static pressure)	24.56CFM(0.696m ³ /min) Min:22.10CFM (0.626m ³ /min)
Air pressure (at zero air flow)	50.90mmH ₂ O (2.004inchH ₂ O) Min:41.23mmH ₂ O (1.623inchH ₂ O)
Acoustical noise	53.8dB(A) Max:56.8dB(A)
Life expectancy	70,000hrs continuous at 40°C , 15~65% relative humidity
Insulation resistance	Min 10Meg Ohm between internal stator and lead wire (+) at 500VDC
Dielectric strength	5mA max at 600VAC 50Hz 1 second between frame and (+) terminal
Operating temperature and humidity	-10 to 70°C ,5% to 90% RH
Storage temperature and humidity	-40 to 70°C ,5% to 95% RH

Noise Test: (ISO10302)

- 1.Measurement within anechoic chamber under free air condition
- 2.Microphone is placed at a distance of 1m on the axis of air intake side
- 3.Chamber background noise max 6.7dB(A)
- 4.Using microphone: G.R.A.S 1/2 inch measure system 40AE+26CA or 1 inch low measure system 40HF
- 5.Test system: National Instrument NI-4474 data acquisition system
- 6.Acoustical noise at rated speed

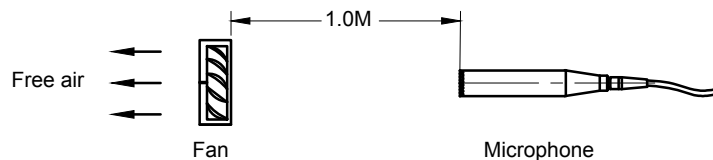

PQ curve: (Rated Voltage or rated voltage at 100%PWM if applied)

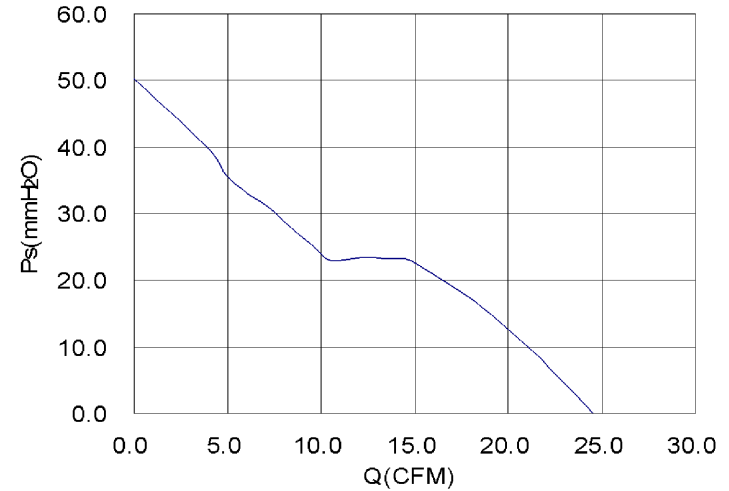

Output of rotary Signal:

- 1.Output method- open collector method
2. Circuit Specification:

- 2-1.Specification:
 Vcc:=13.8V MAX
 Vce(sat):=0.5V MAX
 Ic=5mA MAX
 R Vcc/Ic

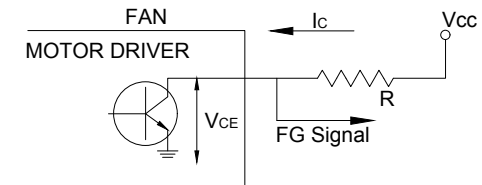

2-2. Frequency Generator Waveform:

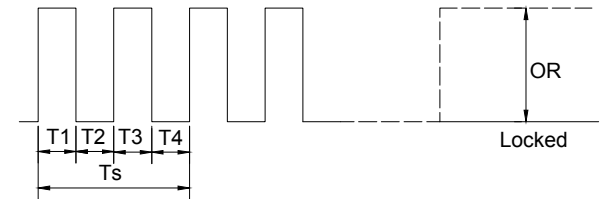

One Fan Rotation
 N: Revolution per minute (rpm).
 $T1 \sim T4 \approx \frac{1}{4} Ts = \frac{60}{4N}$ (sec).
 Pulse width duty = $T1 \div (T1+T2) = 50 \pm 5\%$

PWM Signal:

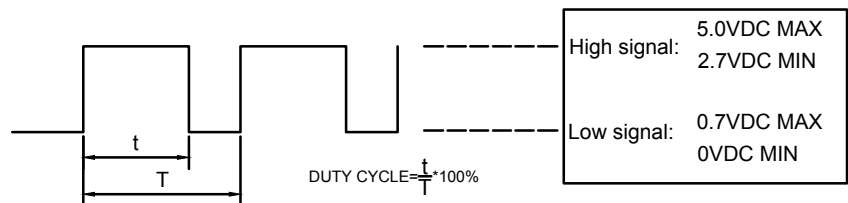

- 1.The control signal frequency of the fan shall be able **18~25** kHz.
- 2.At 100% duty cycle, the rotor will spin at maximum speed.
- 3.With control signal lead disconnected, the fan will spin at maximum speed.

ITEMS	DESCRIPTION		REMARKS	
Frame	PBT+30%GF UL: 94V-0			
Impeller	PBT+30%GF UL: 94V-0			
Weight	45±5g			
Bearing	Two ball			
Housing	N/A			
Terminal	N/A			
Tube	N/A			
Label	ø21mm Material: PET		Protechnic	
Speed Vs duty cycle (12V)	Duty cycle(%)	0%	100%	
	Speed (R.P.M)	0	18000±10%RPM	
PWM test method: From 100% duty-cycle to 0% duty-cycle(At 25°C, rated voltage)				

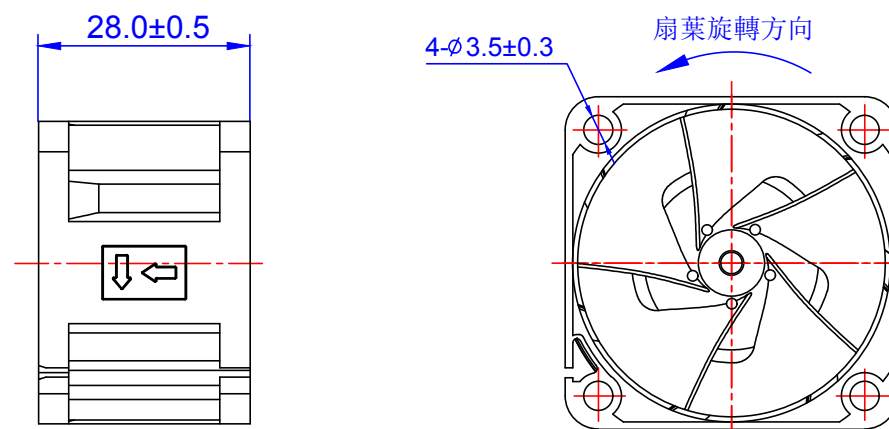
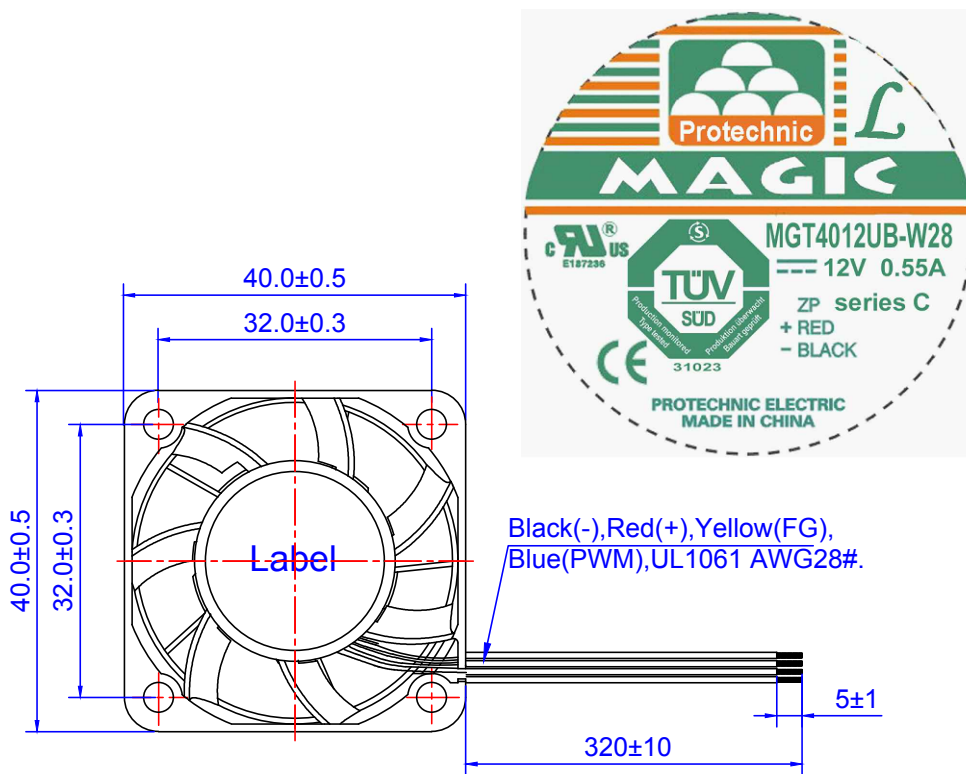

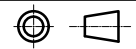
DC BRUSHLESS FAN  Unit mm

 PROTECHNIC ELECTRIC